

## Parts supplied:

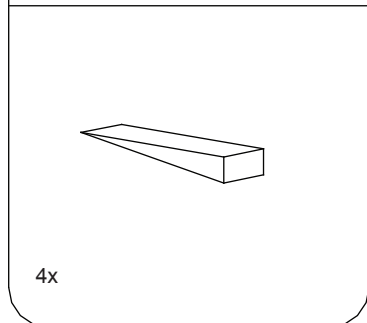
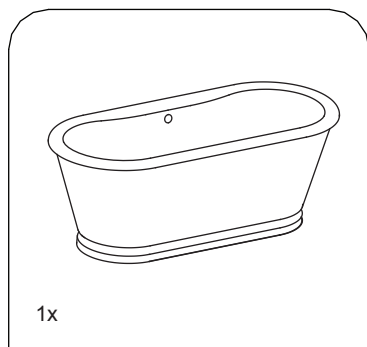

### Important

- Please unwrap the bath and check it carefully to ensure it has not been damaged in handling or transport.
- Please check that all parts have been supplied.
- Assemble bath on a mat to protect against damage to bath surface.
- Please do not remove the old fixture before you unpack and inspect the new unit.
- Store the bath in a safe place until you begin installation to avoid damage.
- Any installation should be carried out by a qualified tradesman with knowledge of statutory plumbing requirements in your area.
- This product requires a two person lift – use proper lifting techniques.
- This installation guide does not include details of waste connection; final decision about installation of waste connection should be taken by a suitably qualified person.

**⚠ Do NOT overtighten the waste as this may cause long term damage to the bath. We recommend to use a torque wrench to tighten the waste by using a torque force between 25 Nm and 50Nm.**

### Care and Maintenance

The bath outer is made from polished stainless steel.

Clean with water or a soft detergent and dry with a soft cloth. Do not use detergents containing hydrochloric acid or caustic or abrasive materials, chemicals or cloths.

Install following the instructions.

### Everyday cleaning

We recommend a non-abrasive bathroom cleaner.

### Warning

Never use cleaners / bleach products specifically manufactured for WC bowl cleaning as they may damage your bath. In addition to these we strongly recommend that applying hair colouring is also not used over the bath as it may de-colour the bath.

Please place your bath identification number here and keep this paperwork in a safe place as you will need this if a problem occurs with your product.

